



BRAKE & CLUTCH PRESSURE BLEEDER KIT 12V

MODEL NO: **VS0207.V3**

Thank you for purchasing a Sealey product. Manufactured to a high standard, this product will, if used according to these instructions, and properly maintained, give you years of trouble free performance.

IMPORTANT: PLEASE READ THESE INSTRUCTIONS CAREFULLY. NOTE THE SAFE OPERATIONAL REQUIREMENTS, WARNINGS & CAUTIONS. USE THE PRODUCT CORRECTLY AND WITH CARE FOR THE PURPOSE FOR WHICH IT IS INTENDED. FAILURE TO DO SO MAY CAUSE DAMAGE AND/OR PERSONAL INJURY AND WILL INVALIDATE THE WARRANTY. KEEP THESE INSTRUCTIONS SAFE FOR FUTURE USE.



Refer to
Instruction
Manual



Wear eye
protection



Wear
protective
gloves

1. SAFETY

1.1. GENERAL SAFETY.

- WARNING!** Ensure Health and Safety, local authority and general workshop practice regulations are adhered to when using this unit.
- IMPORTANT:** If possible, refer to the vehicle manufacturer's service instructions to establish the correct procedure.
- ✓ Maintain this product in good working order and condition, take immediate action to repair or replace damaged parts.
- ✓ Use approved parts only. Unapproved parts may be dangerous and will invalidate the warranty.
- WARNING!** Only use new brake fluid, used brake fluid or other fluids contaminate the system causing possible brake failure.
- ✗ **DO NOT** use to perform a task for which it is not designed.
- ✗ **DO NOT** allow untrained persons to use the unit.
- ✗ **DO NOT** use when tired or under the influence of drugs, alcohol or intoxicating medication.
- WARNING! DO NOT** pollute the environment by allowing uncontrolled discharge of fluids.
- ✓ Keep children and unauthorised persons away from the work area.
- ✓ Keep work area clean and tidy and free from unrelated materials. Ensure the work area has adequate lighting.
- ✓ Ensure that a vehicle which has been jacked up and had its wheels removed, is adequately supported with axle stands.
- WARNING! DO NOT** use with mineral brake fluids unless the machine is manufactured specifically for and dedicated to that purpose. Mineral and conventional fluids do not mix. Cross contamination, however small, between mineral and DOT 3/4/4.1/5 fluids will always result in brake failure.
- ✗ **DO NOT** disconnect universal adaptor from brake fluid reservoir until the unit has been de-pressurised.
- ✓ Dispose of waste brake fluid in accordance with local authority regulations.
- ✓ Always read and comply with the warnings on the brake fluid container.
- ✓ Wear suitable clothing to avoid snagging. **DO NOT** wear jewellery, and tie back long hair. A full range of personal safety equipment is available from your Sealey stockist.
- ✓ When not in use, clean unit and store in a safe, dry, childproof location.

1.2. PERSONAL PRECAUTIONS

- ✓ Wear safety eye protection and protective clothing. Avoid touching eyes while working near battery.
- ✓ Wash immediately with soap and water if battery acid contacts skin or clothing. If acid enters eye, flush eye immediately with cool, clean running water for at least 15 minutes and seek immediate medical attention.
- ✓ Remove personal metallic items such as rings, bracelets, necklaces and watches. A lead-acid battery can produce a short-circuit current which is high enough to weld such items to the vehicle and cause severe burns.
- ✗ **DO NOT** smoke or allow a spark or flame in the vicinity of the battery or engine.
- WARNING!** To prevent the risk of sparking, short circuit and possible explosion **DO NOT** drop metal tools in the battery area, or allow them to touch the battery terminals.
- ✗ **DO NOT** cross-connect unit to battery. Ensure positive (RED) clamp is to positive terminal and negative (BLACK) clamp is to negative terminal.
- WARNING!** Brake fluid is hazardous, wear approved eye protection and keep skin contact to a minimum. If brake fluid enters eyes, rinse immediately with plenty of water and seek medical advice. If swallowed seek medical advice immediately.
- WARNING!** Brake fluid is flammable - keep away from sources of ignition, including hot surfaces e.g. exhaust manifold.
- WARNING!** Brake fluid will damage paintwork and clothing. Any spillages should be flushed with water immediately.

2. INTRODUCTION

Powered by the vehicle's own 12V battery. Allows single-handed bleeding of the vehicle's brake or clutch system and unit is fitted with a long, high pressure hose. Bleed pressure is closely controlled up to 2.5bar - suitable for most vehicles (even those with ABS). Unit fitted with auto-shut-off device to prevent the system running dry and is supplied with a variety of European, Japanese and US vehicle adaptors, bleed bottle and fluid extractor. Tank Capacity: 2L. Cable/Hose Length: 4/5m.

3. SPECIFICATION

Model No: VS0207.V3
 Power Supply: 12V
 Maximum Pressure: 2.5bar
 Nett Weight: 11.46kg
 Cable Length: 4m
 Hose Length: 5m
 Tank Capacity: 2L

4. CONTENTS

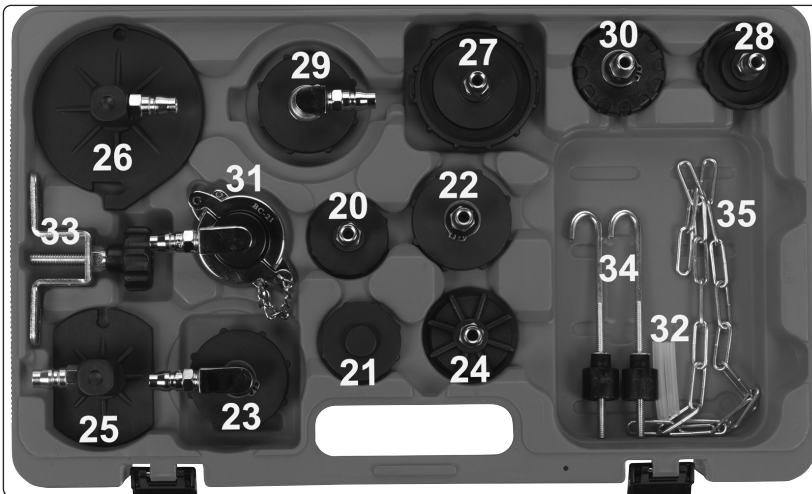

Item	Part no.	Description	Applications	Internal dia.	Type
20	VS0204.V4-20	ADAPTOR CAP '1'	Chrysler, Jeep	43.5	Bayonet
21	VS0204.V4-21	ADAPTOR CAP '2'	Chrysler, Jeep (Blanking cap)	43.5	Bayonet
22	VS0204.V4-22	ADAPTOR CAP '3'	GM, Chevrolet, Hummer, Mazda	49.5	Bayonet
23	VS0204.V4-23	ADAPTOR CAP '3' 90° ELBOW	Ford Fiesta 2011 onwards	49.5	Bayonet
24	VS820SA	ADAPTOR CAP '6'	Most European manufacturers	42	Thread
25	VS0204.V4-25	ADAPTOR CAP '7'	Universal	N/A	Rubber cone 30-55mm
26	VS0204.V4-26	ADAPTOR CAP '8'	Universal	N/A	Rubber cone
27	VS0204.V4-27	ADAPTOR CAP '9'	Honda	56	Bayonet
28	VS0204.V4-28	ADAPTOR CAP '10'	Nissan	34.5	Bayonet
29	VS0204.V4-36	ADAPTOR CAP '41'	Ford Mondeo 2014 onwards, Ford Fiesta 2016 onwards, Mazda CX3/CX5	49.5	Bayonet
30	VS0204.V4-30	ADAPTOR CAP '19'	Chrysler, Hyundai, Mitsubishi, Nissan, Subaru	50.7	Bayonet
31	VS0204.V4-31	ADAPTOR CAP '21' 90° ELBOW	Toyota, Lexus	46.5	
32	VS0204.V4-32	ADAPTORS (c/w TUBES)			
33	VS0204.V4-33	CLAMP ASSEMBLY			
34	VS0204.V4-34	HOOK BOLT			
35	VS0204.V4-35	CHAIN			
Fig.1	VS0207.V3	Unit			

5. OPERATION

- ❑ **WARNING! Familiarise yourself with the hazards of brake fluid - read the manufacturer's instructions on the container.**

5.1. Preparing unit for use.

- 5.1.1. Before using on a vehicle for the first time, it is necessary to bleed all air out of the unit's system.
- 5.1.2. Half fill the unit's reservoir with fluid of the required specification, but do not replace the filler cap, connect the power cable to a suitable battery, ensuring that the power switch (fig.2) is in the "off" position and the pressure relief valve (fig.2) is at the closed (fully clockwise) position.
- 5.1.3. Attach the adapter to the pressure delivery hose quick-fit coupling at the end of the bleed pipe. Hold the cap over the open neck of the unit reservoir so that fluid will be expelled from the adapter into the reservoir.
- 5.1.4. Turn the unit to the "on" position at the switch (fig.2), as brake fluid is drawn through the unit, air will be expelled from the system.
- 5.1.5. Increase the pressure by turning the pressure relief valve (fig.2) halfway between its maximum and minimum positions. When fluid without any air bubbles present flows from the delivery hose, turn the unit off.

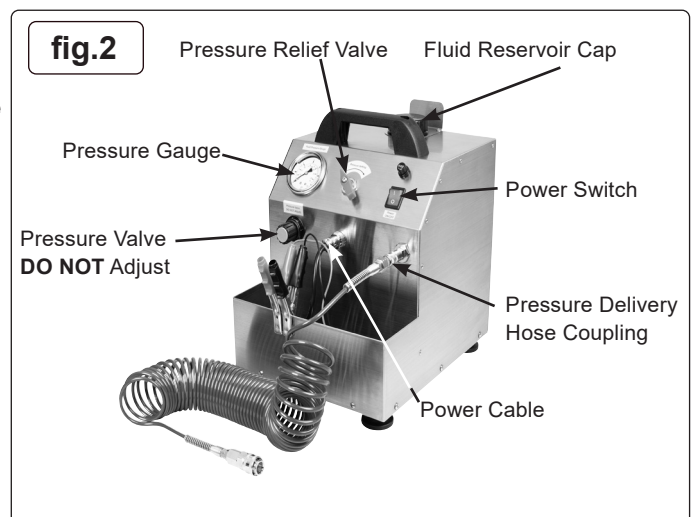

5.1.6. Remove the adapter from the open top of the unit reservoir and replace the filler cap. Further bleeding will not be required unless the bleed pipe is disconnected from the hose's quick fit coupling. The unit is now ready to use.

5.2. **Brake bleeding procedure.**

DO NOT touch the vehicle's brake pedal whilst bleeding the brakes.

5.2.1. Refer to the vehicle manufacturer's instructions for brake bleeding and wheel sequence before proceeding. If no specific instructions from the vehicle manufacturer exist, follow the instructions detailed below. If the manufacturer has not supplied a specific figure for the maximum pressure for this operation, it is advised to keep the pressure within the 1.5 to 2Bar range, to avoid damaging the brake fluid reservoir etc.

5.2.2. Fully prepare the vehicle by jacking it up or by using a ramp, remove the wheels from the vehicle as required to gain access, so that work can commence as soon as the unit is turned on.

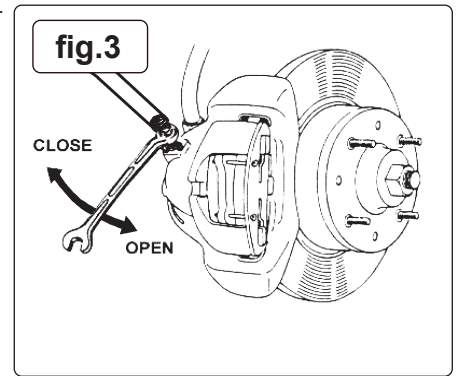

5.2.3. Remove the cap on the vehicle's brake fluid reservoir. If the brake fluid level is not at its maximum level, top it up, ensuring that there is some air space above the fluid. Fit the required adaptor to the brake fluid reservoir, tighten it and ensure that there is a good seal.

5.2.4. Connect the pressure delivery hose's quick connector to the universal adaptor.

5.2.5. Rotate the pressure relief valve (fig.2) on the unit clockwise and switch on the unit. Adjust the pressure by rotating the pressure relief valve anti-clockwise to the required pressure on the gauge (fig.2), not exceeding 2Bar. The pump will stop automatically when the required pressure is reached. If the slight pulsing of the pump is not required or a lower pressure is desired, turn the pressure relief valve slightly clockwise.

5.2.6. Starting with the wheel furthest away from the brake fluid reservoir, connect one end of a tube from a bleed bottle to the brake nipple and, using a brake spanner, open the nipple approximately ¼ turn (fig.3), brake fluid will flow through the clear pipe into the bottle, when there are no visible bubbles in the fluid, tighten the bleed nipple and remove the pipe, taking care not to spill any brake fluid.

5.2.7. Repeat the procedure at each location in turn, as required.

5.2.8. When finished, check all bleed nipples are closed and turn the unit off. Slowly vent the pressure by rotating the pressure relief valve (fig.2) anti-clockwise until the correct level of fluid is reached in the vehicle reservoir. When the correct fluid level is achieved, disconnect the quick fit coupling connector from the universal adaptor.

5.2.9. Remove the adapter from the vehicle reservoir, taking care not to spill any brake fluid. Disconnect the battery leads.

5.2.10. Check the fluid level and refit the vehicle's brake fluid reservoir cap.

5.3. **Changing the brake fluid.**

5.3.1. Carry out the brake bleeding procedure as described in 5.2.

5.3.2. Allow a longer period of time when bleeding, to allow the new fluid to flush out the old fluid. When new fluid can be seen in the clear tube, tighten the brake nipple.

5.3.3. Repeat this procedure at each wheel in turn.

5.3.4. Disconnect as above (5.2.6. to 5.2.8.).

NOTE: When brake bleeding and/or brake fluid changing is complete, test the action of the brake pedal to ensure that the brakes are working correctly and are not spongy, before taking the vehicle onto the road.

5.4. **Clutch bleeding procedure.**

5.4.1. Refer to the relevant vehicle manufacturer's instructions for clutch bleeding procedure.

5.4.2. If no specific instructions from the vehicle manufacturer exist, the same basic procedures as for brake bleeding can be followed.

5.4.3. Dispose of all waste brake fluid responsibly. Contact your local authority for details.

6. MAINTENANCE

6.1. Check the brake fluid in the unit before each operation and observe level during operation to ensure that the level never falls below 3cm. (Top up as required, even during bleeding operation). If fluid level drops enough to allow air into the pump of the unit, it will be necessary to re-bleed the unit as described in para. 5.1

6.2. The pump in the unit has an automatic over current reset instead of a fuse. (Reset will take approximately 2 minutes from switch off).

6.3. If the pump is not to be used for a long period, providing the cap remains closed, the stored brake fluid in the unit will not deteriorate over time, due to the dry air inside. Wipe unit clean with a dampened cloth, before storing it away in a safe, dry childproof location.

6.4. There are no regularly serviceable parts to the unit, it should be returned to an authorised Sealey agent for repair if needed.



ENVIRONMENT PROTECTION

Recycle unwanted materials instead of disposing of them as waste. All tools, accessories and packaging should be sorted, taken to a recycling centre and disposed of in a manner which is compatible with the environment. When the product becomes completely unserviceable and requires disposal, drain any fluids (if applicable) into approved containers and dispose of the product and fluids according to local regulations.



WEEE REGULATIONS

Dispose of this product at the end of its working life in compliance with the EU Directive on Waste Electrical and Electronic Equipment (WEEE). When the product is no longer required, it must be disposed of in an environmentally protective way. Contact your local solid waste authority for recycling information.

Note: It is our policy to continually improve products and as such we reserve the right to alter data, specifications and component parts without prior notice. Please note that other versions of this product are available. If you require documentation for alternative versions, please email or call our technical team on technical@sealey.co.uk or 01284 757505.

Important: No Liability is accepted for incorrect use of this product.

Warranty: Guarantee is 12 months from purchase date, proof of which is required for any claim.

Jack Sealey Ltd t/a Sealey Group, Kempson Way, Suffolk Business Park, Bury St Edmunds, Suffolk, IP32 7AR UK
Jack Sealey (EU) Ltd t/a Sealey Group, Farney Street, Carrickmacross, Co. Monaghan, A81 PK68 Ireland
Tel: 01284 757500 • **Email:** sales@sealey.co.uk • **Web:** www.sealey.co.uk